c **UL** <sup>®</sup> US**CB****FEATURES**

- 80W with 8.6CFM forced air-cooling, 60W convection cooling
- Compact size with ATX output
- PG/PF Signal
- +5V Stand by & Remote On/Off
- MTBF>130,000 hr. MIL-217F.

**1. Description**

MPI-806H is a compact size, ATX output power supply for industrial and embedded system application. The device utilizes a thermally efficient U channel chassis design. Designed to be convection cooling but however provided with optional cover and fan for customers' reference.

Output Voltage	Min. Output Current	Rated Output Current	Max. output Current <sup>(Note 1)</sup>	Line Regulation	Load Regulation	Ripple & Noise p-p <sup>(Note 2)</sup>	Initial Setting Accuracy <sup>(Note 3)</sup>
+5V	0.5A	5A	8A	1%	2%	50mV	5.08V to 5.13V
+12V	0A	1.5A	3A	1%	4%	120mV	11.4V to 12.6V
-12V	0A	0.5A		1%	5%	120mV	-11.4V to -12.6V
+3.3V	0A	4A	6A	1%	4%	50mV	3.10V to 3.50V
+5Vsb	0A	0.75A		1%	4%	120mV	4.80V to 5.20V

**Total Output Power:** 80W at 50°C environment temperature <sup>(Note 4)</sup>.

Note: 1) The maximum total combined output power on the +3.3V and +5V rails is 40W.

2) Measured by a 20MHz bandwidth limited oscilloscope and the each output is connected with a 10μF Electrolytic Capacitor and a 0.1μF Ceramic Capacitor.

3) The +5V output is set between 5.08V to 5.13V by variable resistor and all output at 60% rated load and the other outputs are checked to be within the accuracy range.

4) Total maximum load cannot exceed 80W with 8.6 CFM forced air-cooling and 60W convection cooling.

**2. Input Specification**

Parameter	Conditions/Description	Min.	Nom.	Max.	Units
Input Voltage	Continuous input range.	90	115/230	264	VAC
Input Frequency	AC input.	47		63	Hz
Hold Up Time	Nominal AC Input Voltage (230VAC), rated load.	20			ms
Input Current	Nominal AC Input Voltage (115VAC/230VAC), rated load.			2/1	A
Inrush Current	Nominal AC Input Voltage (115VAC/230VAC), one cycle at 25°C.			30/60	A
Input Protect	Non-user serviceable internally located AC input line fuse.				

**3. Output Specification**

Parameter	Conditions/Description	Min.	Nom.	Max.	Units
Efficiency	Rated load, 115VAC. Varies with distribution of loads among output.		70		%
Minimum load					See Chart of Description
Ripple & Noise	Rated load, 20MHz bandwidth				See Chart of Description
Output Power	Continuous output power.				See Chart of Description
Line Regulation	Less than ±1% at rated load with ±10% changing in input voltage.				See Chart of Description
Load Regulation	Measured from 60% to 100% rated load and from 60% to 20% rated load (60% ±40% rated load) for each output, and others voltage setting at 60%.				See Chart of Description
Turn-on Delay	Time required for initial output voltage stabilization	0.3		4	Sec



#### 4. Interface Signals and Internal Protection

Parameter	Conditions/Description
Power On/Off	The power supply will be turned on when the power On/Off pin is connected to secondary GND.
Power Good Signal	When power is turned on, the power good signal will go high 100ms to 500ms after all output DC voltages are within regulation limits.
Power Fail Signal	The power fail signal will go low at least 1 mS before any of the output voltages fall below the regulation limits.
Over Load Protection	Fully protected against output overload and short circuit. Automatic recovery upon of overload condition.
Over Voltage Protection	For some reason the power supply fails to control itself, the build-in over voltage protection circuit will shut down the outputs to prevent damaging external circuits. The trigger point is about 6.5-8.5V at +5V. If the OVP occur, PSU cannot be recovered.

#### 5. Safety Approvals, EMI and EMS Specification

Parameter	Conditions/Description	Min.	Nom.	Max.	Units
Safety Approvals	UL, UL 60950, 3rd edition CB, IEC 60950-1 TUV, EN 60950-1: 2001			Approved	
Hi-Pot	Input to output	4242			VDC
Hold Up Time	Nominal AC Input Voltage (230VAC), rated load.	20			mS
Radiation	EN 55022 / CISPR 22 & FCC Part 15	B			Class
Conduction	EN 55022 / CISPR 22 & FCC Part 15	B			
EMS	IEC 61000-4-2, 8KV air discharge and 6KV contact discharge	3			Level
	IEC 61000-4-3, 3V/M	2			
	IEC 61000-4-4, 2KV line & PE	3			
	IEC 61000-4-5, 2KV	3			
	IEC 61000-4-6, 10V	3			
	IEC 61000-4-8, 10A/M IEC 61000-4-11	3			

#### 6. Environment Specification

Parameter	Conditions/Description	Min.	Nom.	Max.	Units
Operating Temperature	Derate linearly above 50°C by 2.5% per °C At 100% load: to a maximum temperature of 70°C At 50% load:	0		50 70	°C
Storage Temperature		-40		+70	°C
Relative Humidity	Non-condensing.	5		95	%RH
Altitude	Operating			10K	Feet
	Non-operating			40K	

#### 7. Mechanical Specification

Parameter	Conditions/Description
Dimension	128 x 81 x 40 mm, Tolerance +/- 0.4mm.
Connector	CN1 --- AC input: Molex 5273-03A with draw 1 pin or equivalent. CN2 --- DC output: Molex 5273-12A or equivalent. CN3 --- DC output: Molex 5045-03A.
Pin Assignment	CN1 Pin 1. N 2. L
	CN2 Pin 1. 3.3V 2. 3.3V 3. GND
	CN3 Pin 1. +5Vsb 2. GND
	7. +5V 8. +5V 9. +5V 10. PG/PF 11. +12V 12. -12V 3. PS on/off

#### 8. Options

Parameter	Conditions/Description
Cable (No. 866-806H)	ATX connector, HDD connector x 2, FDD connector x 1



◆ Dimension

Unit: mm; tolerance +/- 0.4mm

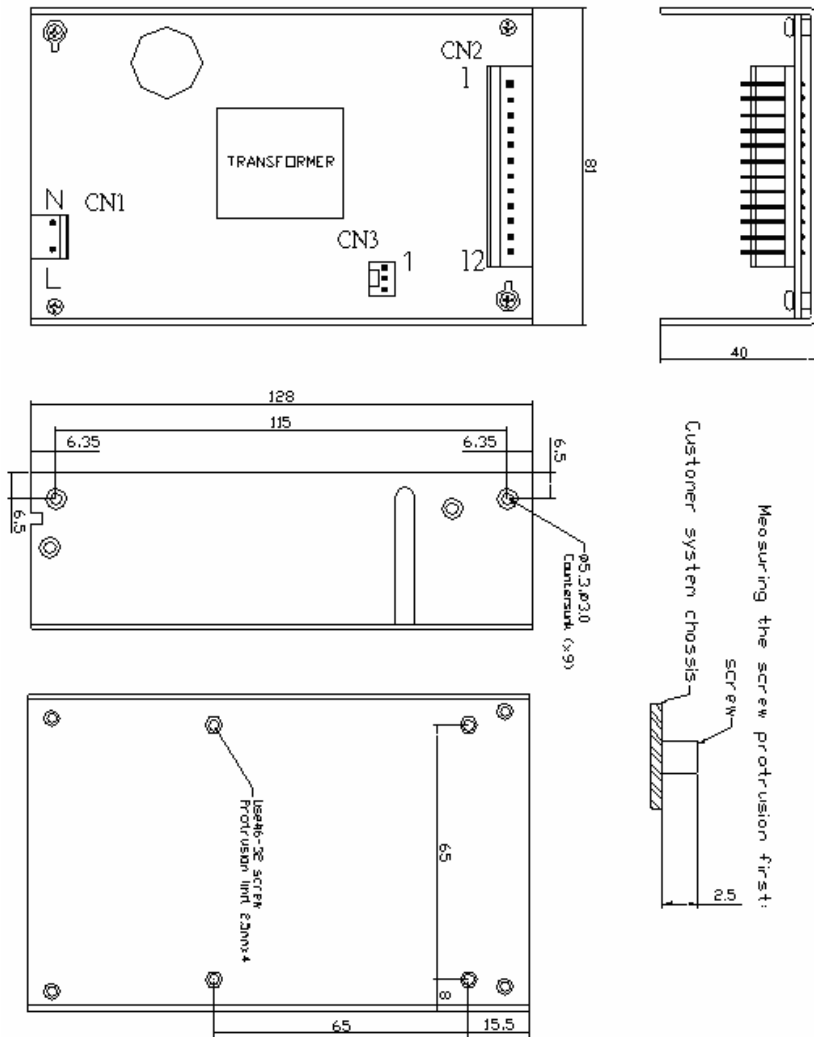

◆ Cable (No. 866-806H)

- 12. Blue(-12V)
- 11. Yellow(+12V)
- 10. Grey(PG/PF)
- 9. Red(+5V)
- 8. Red(+5V)
- 7. Red(+5V)
- 6. Black(GND)
- 5. Black(GND)
- 4. Black(GND)
- 3. Black(GND)
- 2. Orange(3.3V)
- 1. Orange(3.3V)

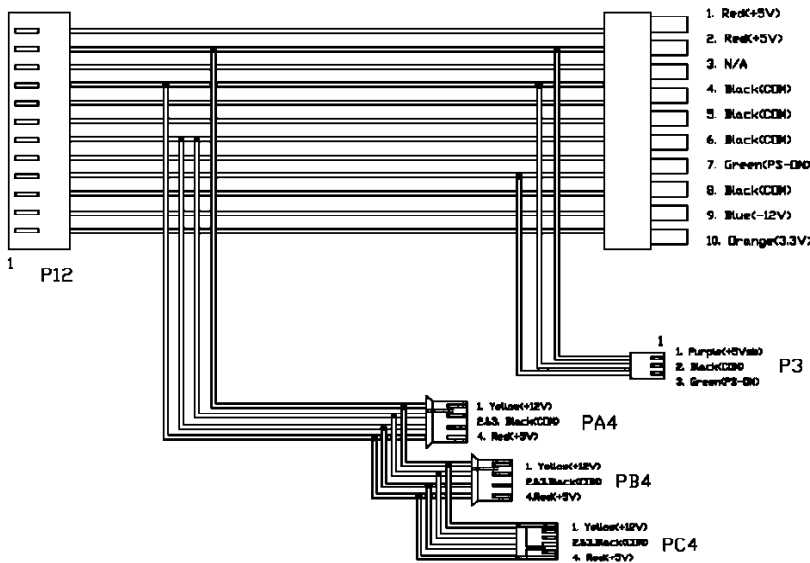

- 11. yellow(+12V)
- 12. Purple(+5Vsb)
- 13. Grey(PG/PF)
- 14. Black(GND)
- 15. Red(+5V)
- 16. Black(GND)
- 17. Red(+5V)
- 18. Black(GND)
- 19. Orange(3.3V)
- 20. Orange(3.3V)

Connector	Length (mm)	AWG
P20	270	18
P3	300	22
PA4	120	18
PB4	120	18
PC4	120	22
Tolerance±20-10mm		