

SPECIFICATION

For

SWITCHING POWER SUPPLY

M/N: MPE-K256(-C)

Revision History

Version	Revise Date	Change Items
Rev. 01	Oct. 10. 2012	Established.
Rev. 02	Jan. 11. 2013	Updated.
Rev. 03	Mar. 6 2013	Updated the performance.
Rev. 04	Apr. 29. 2013	Added input voltage derating specification.
Rev. 05	May. 27 2013	Revised the condition of turn-on delay; Updated the mechanical drawing.
Rev. 06	Oct. 3. 2014	Add optional cover drawing and derating curve.
Rev. 07	Jan. 3. 2018	1. Changed form. 2. Added EN 55032.
Rev. 08	Jul. 2. 2018	Changed mechanical diagram.

MPE-K256(-C)

250W AC / DC



FEATURES

- ✓ 250W convection-cooled at wide-range ambient.
- ✓ Active power factor correction.
- ✓ High efficiency up to 90%.
- ✓ 1U form factor.
- ✓ < 0.5W no-load power consumption.
- ✓ Remote sense & built-in fan supply.
- ✓ PG / PF signal.
- ✓ Optional cover-kit.
- ✓ Design to meet standard IEC 60950-1 & EN 60950-1 & UL 60950-1, 2nd edition.
- ✓ Meets EMI CISPR/FCC class B.
- ✓ Optional cover kits.



Models & Ratings

Model Number	Wattage	Output Voltage	Min. Current	Rated Current
MPE-K256	250 W	+48 V	0 A	5.3 A
		+12 V (Fan)	(Note2)	0.2 A

Total Output Power: Max. 250W convection cooled at 50°C environment temperature. Max. 250W with 11.7 CFM at 70°C environment temperature. (Note 1)

1. Air flow from the top to the body of PSU with distance 50 mm maximum, and also see the performance curves.
2. To stabilizing the fan supply, the unit needs min. load 10W on main output.
3. Model no. coding:

MPE-K256-Y-Z

1
2

①

Y =	Input / Output Connector Type
blank	Molex Type Connector (Standard Product) or equivalent
J	JST Type Connector or equivalent
Please see the detail in Mechanical Details	

②

Z =	Cover kit
blank	Open frame
C	With cover kit

Summary Mechanical Details

Characteristic	Minimum	Typical	Maximum	Units	Notes & Conditions
Input Range	85	115 / 230	264	VAC	Continuous input range.
	125		373	VDC	
Label Voltage	100		240		
Input Frequency	47	50 / 60	63	Hz	AC input.
Efficiency	88	89	90	%	At input 230VAC, rated load, above 0.5 hr. warm up.
Average Efficiency	87			%	Measured at nominal AC input voltage (115 / 230VAC) with 25%, 50%, 75% and 100% load above 0.5 hr. warm up.
Operation Temperature	-20		+70	°C	Derate linearly above 50°C by 1.5% per °C to a maximum temperature of 70°C at 50% load.
Weight		470.4		g	
Dimensions	152.4 (L) x 101.6 (W) x 41.0 (H) mm, Tolerance +/- 0.4mm.				
EMC	EN 55022 / EN 55032, CISPR 22 & FCC Part 15, EN 61000-3-2, EN 61000-3-3, EN 61204-3, IEC 61000-4-2, IEC 61000-4-3, IEC 61000-4-4, IEC 61000-4-5, IEC 61000-4-6, IEC 61000-4-8, IEC 61000-4-11				
Safety Approvals	IEC 60950-1, 2 nd edition, EN 60950-1, 2 nd edition, UL 60950-1, 2nd Edition, CSA C22.2 No. 60950-1-07, 2nd Edition				

Input

Characteristic	Minimum	Typical	Maximum	Units	Notes & Conditions
Input Voltage	85	115 / 230	264	VAC	Continuous input range.
	125		373	VDC	
Label Voltage	100		240		
Input Frequency	47	50 / 60	63	Hz	AC input.
Input Current			3.5	A	Nominal AC Input Voltage (115VAC/230VAC), rated load.
Inrush Current			30 / 60	A	Nominal AC Input Voltage (115VAC/230VAC), one cycle at 25°C.
No-load power consumption			0.3 / 0.5	W	Nominal AC Input Voltage (115/230VAC), without fan connected. Only with model MPE-K256
Power Factor	0.9				
Input Protection	One non-user serviceable internally located AC input line fuse. Fuse : 5A / 250VAC * 1pcs				

Output

Characteristic	Minimum	Typical	Maximum	Units	Notes & Conditions
Output Voltage		48		VDC	
		12(Fan)			
Initial Set Accuracy	47.6		48.4	%	Initial setting accuracy is at Input 115VAC and output at 60% rated load.
Minimum Load		0		A	
Start Up Delay		1	1.5	Sec	At input 115VAC, 100% rated load, 25°C.(Note 1)
Hold Up Time	20			mS	Nominal AC Input Voltage (115VAC), rated load.
Line Regulation		±1.0		%	Less than ±1% at rated load with ±10% changing in input voltage 115VAC.
Load Regulation		±1.0		%	Measured from 60% to 100% rated load and from 60% to 20% rated load (60% ±40% rated load).
Ripple & Noise		480		mV	Rated load, measured by a 20MHz bandwidth limited oscilloscope and the each output is connected with a 10µF Electrolytic Capacitor and a 0.1µF Ceramic Capacitor.
Leakage Current			1	mA	At input 264VAC, 63Hz, rated load.
Overvoltage Protection	For some reason the power supply fails to control itself, the build-in over voltage protection circuit will auto recovery the outputs to prevent damaging external circuits, the trigger point is around 110%~135% of output voltage.				
Short Circuit Protection	Fully protected against output overload and short circuit. Automatic recovery upon of overload condition.				
Remote Voltage Sense	Compensates for wire voltage drop.				
PG signal	When power is turned on, the power good signal will go high 100ms to 500ms after all output DC voltages are within regulation limits.				
PG signal	The power fail signal will go low at least 1ms before the output voltages fall below the regulation limits.				

Note:

1. Defined at AC input voltage only.

General

Characteristic	Minimum	Typical	Maximum	Units	Notes & Conditions
Efficiency	88	89	90	%	At input 230VAC, rated load, above 0.5 hr. warm up.
Average Efficiency	87			%	Measured at nominal AC input voltage (115 / 230VAC) with 25%, 50%, 75% and 100% load above 0.5 hr. warm up.
Isolation	IP to OP	3000		VAC	
	IP to GND	2500		VAC	
	OP to GND	500		VAC	
Switching Frequency		65		KHZ	

Environmental

Characteristic	Minimum	Typical	Maximum	Units	Notes & Conditions
Operating Temperature	-20		+70	°C	Derate linearly above 50°C by 1.5% per °C to a maximum temperature of 70°C at 50% load.
Storage Temperature	-40		+85	°C	
Relative Humidity	5		95	%RH	Non-condensing.
Cooling	11.7			CFM	Forced-cooled when > 250W
Operating / Non-Operating Altitude		3000 / 4000		m	

Derating curve

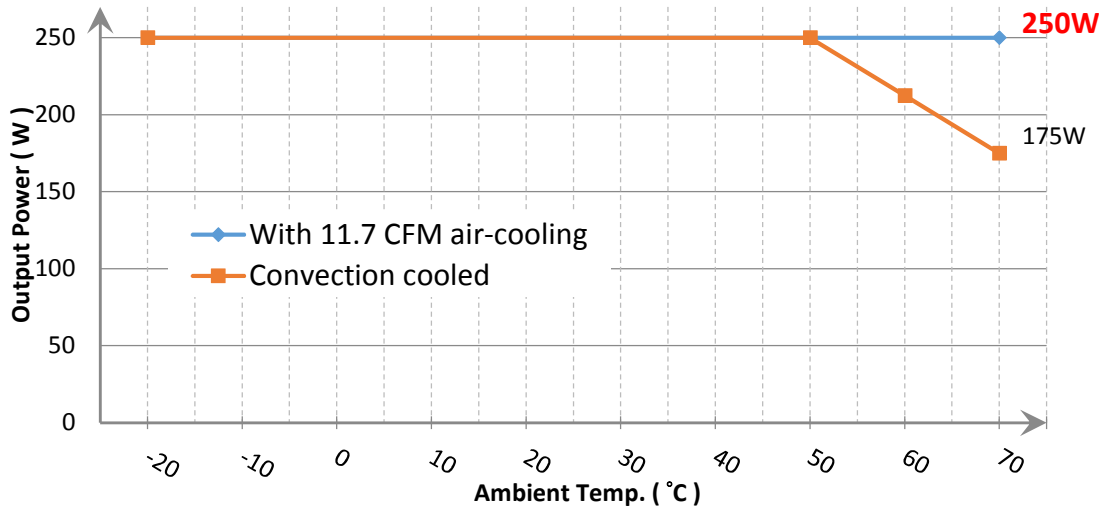

Performance of MPE-K256

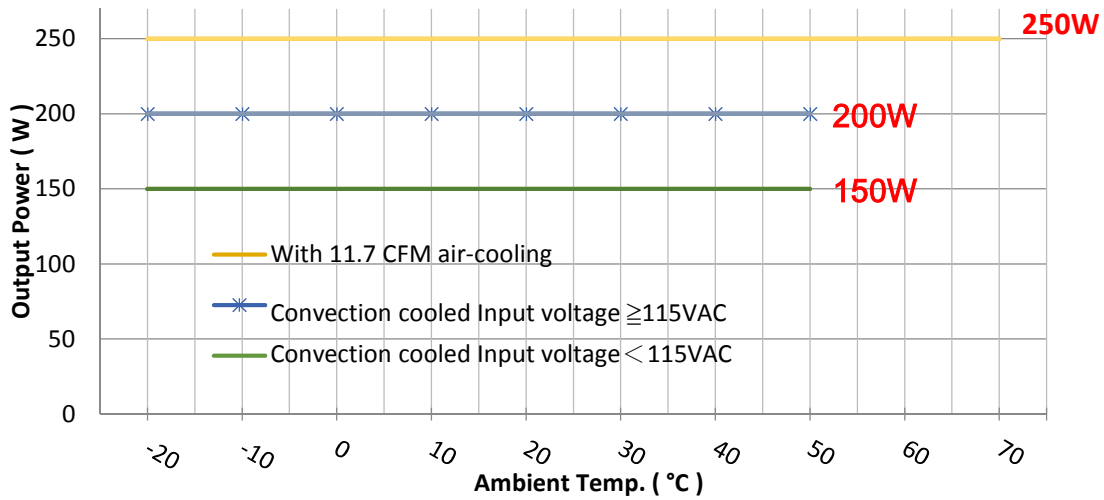

Performance of MPE-K256-C Series

EMC: Emissions

Phenomenon	Standard	Class	Notes & Conditions
Conducted	EN 55022 / EN 55032 CISPR 22 & FCC Part 15	B	
Radiated	EN 55022 / EN 55032 CISPR 22 & FCC Part 15	B	
Harmonic	EN 61000-3-2	D	
Voltage Flicker	EN 61000-3-3		

EMC: Immunity

Phenomenon	Standard	Criteria	Notes & Conditions
ESD	IEC 61000-4-2	A	±8KV air discharge, ±6KV contact discharge
Radiated	IEC 61000-4-3	A	10V/m
EFT	IEC 61000-4-4	A	±2KV Line & PE
Surges	IEC 61000-4-5	A	L-N:±1KV, L/N-PE:±2KV
Conducted	IEC 61000-4-6	A	10V
Power Magnetic	IEC 61000-4-8	A	10A/m
Dips and Interruptions	IEC 61000-4-11	A A A / B C	DIP: >95%, 0.5 cycle DIP: 30%, 25 cycles DIP: 60%, 5 cycles ^(Note 2) INT: >95%, 250 cycles

- Note:
- Above specification is applied with output equal or below 250W. For higher output power, please re-confirm with us.
 - The test result of input 240Vac / 100Vac is criteria A / B.
 - As a build-in type power supply, the power supply needs to be installed in a suitable enclosure to pass the EMI/EMC tests. The final assembly has to comply with the valid EMI/EMC and safety.

Safety Approvals

Safety Agency	Safety Standard	Notes & Conditions
TUV	EN 60950-1, 2 nd edition	CE declaration.
CB	IEC 60950-1, 2 nd edition	Approved.
UL/cUL	UL 60950-1, 2nd Edition, CSA C22.2 No. 60950-1-07, 2nd Edition	Approved.

MPE-K256(-C)

250W AC / DC

Mechanical Details

M/N: MPE-K256

Unit: mm

SIZE : 152.4(L) x 101.6(W) x 41.0(H)mm, Tolerance +/-0.4mm.

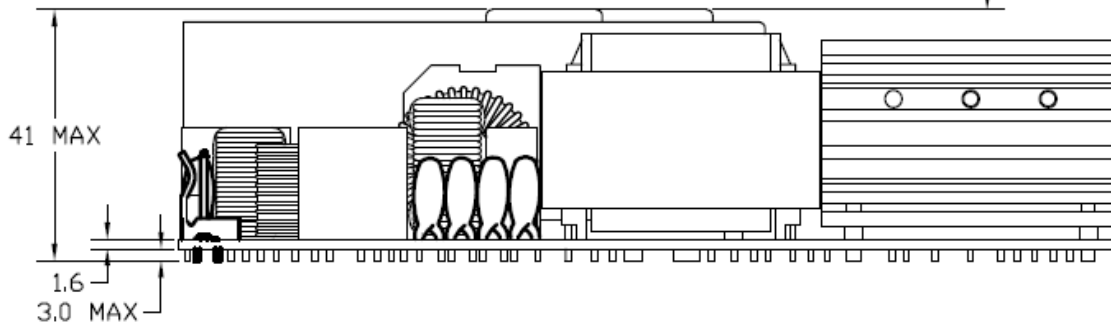
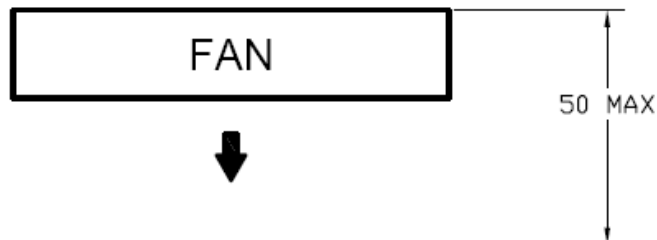
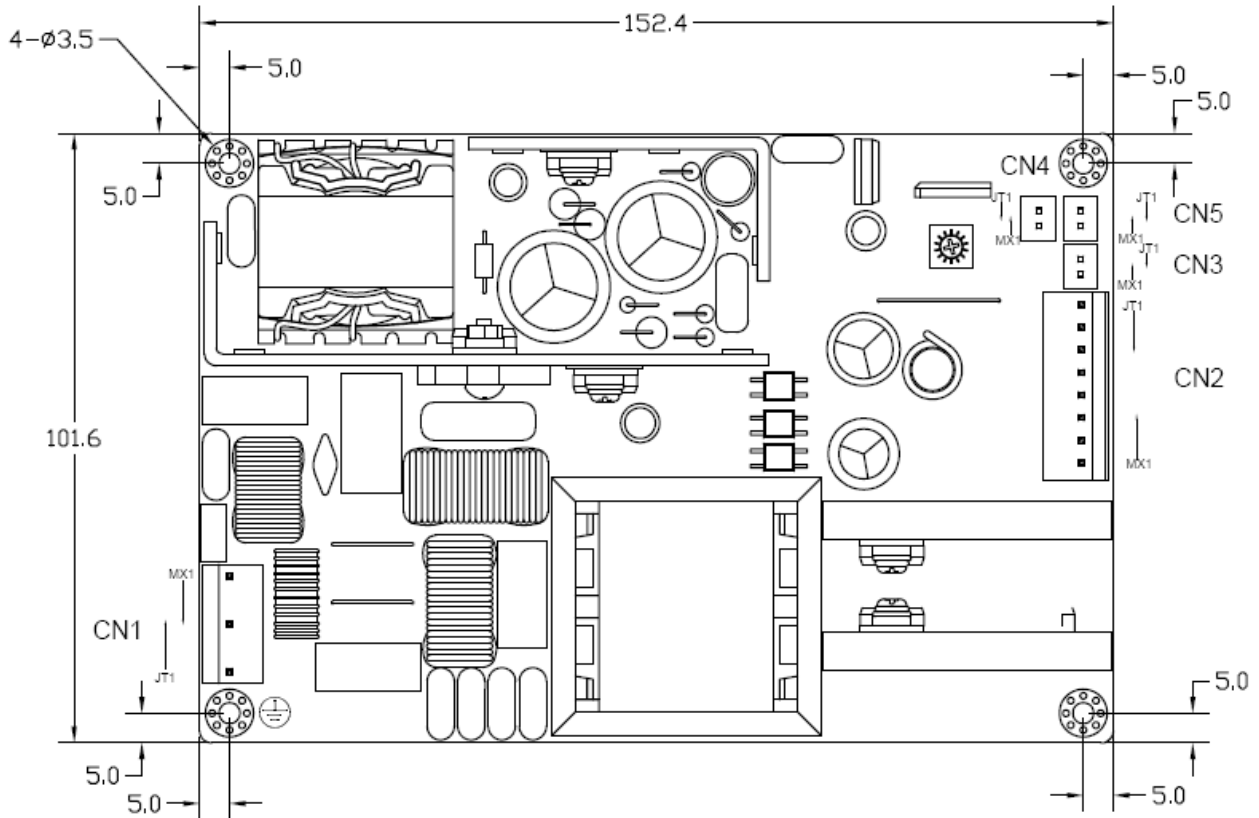

Note: Air cooling if necessary, please see performance curves

MPE-K256(-C)

250W AC / DC

Mechanical drawing MPE-K255-C, 192.4 x 160 x 49.5mm, Tolerance +/- 0.5mm.

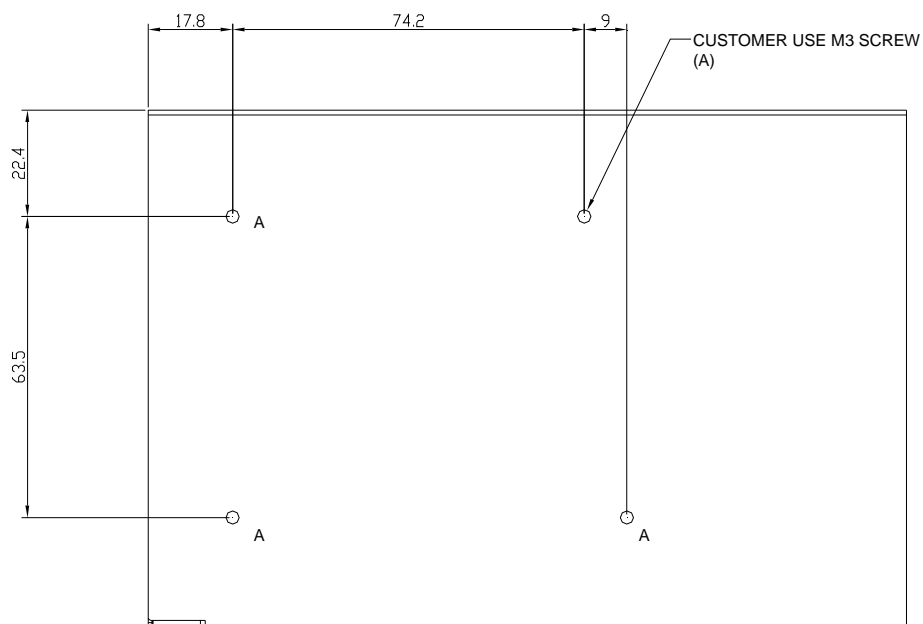
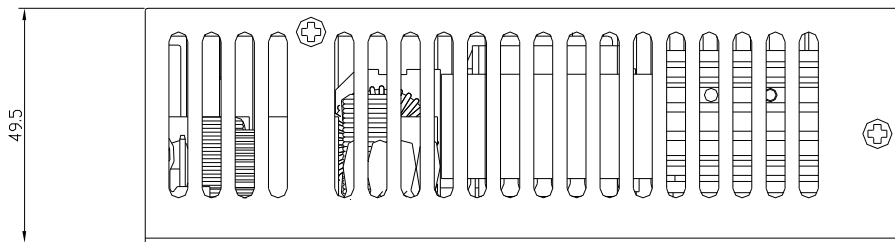
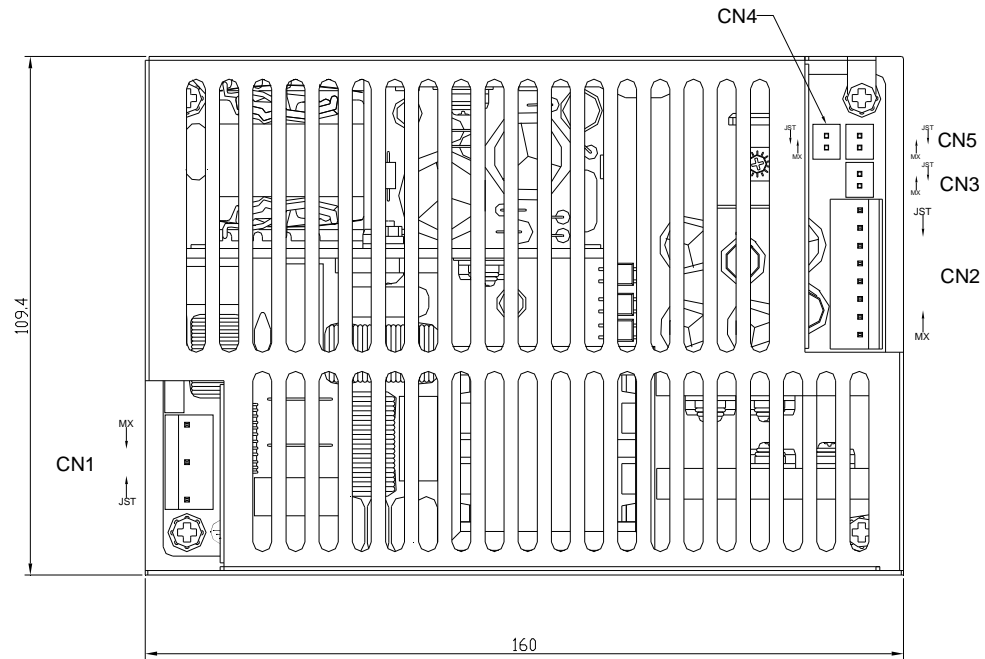

Parameter	Conditions/Description					
Dimension	152.4 (L) x 101.6 (W) x 41 (H) mm, Tolerance +/- 0.4mm.					
Connector & Pin Assignment	Location	Pin (Note 1)	Assignment	Proposed Housing	Proposed Terminals	
CN1 (Input)		MX 5	JT 1	FG	a. MOLEX: 09-50-1051 (5195-05) or 09-52-4054 (5239-05) or equivalent b. JST: VHR-5N or equivalent (Note 2)	a. MOLEX: 5194 or 5225 2478, 2578, 5167 or 5168 or equivalent b. JST: SVH-21T-P1.1 or equivalent
		MX 4	JT 2	N/A		
		MX 3	JT 3	AC in (N)		
		MX 2	JT 4	N/A		
		MX 1	JT 5	AC in (L)		
CN2 (Output)		MX 8	JT 1	0 V	a. MOLEX: 09-50-1081 (5195-08) or 09-52-4084 (5239-08) or equivalent b. JST: VHR-8N or equivalent (Note 2)	a. MOLEX: 5194 or 5225 2478, 2578, 5167 or 5168 or equivalent b. JST: SVH-21T-P1.1 or equivalent
		MX 7	JT 2	0 V		
		MX 6	JT 3	0 V		
		MX 5	JT 4	0 V		
		MX 4	JT 5	+ V		
		MX 3	JT 6	+ V		
		MX 2	JT 7	+ V		
CN3		MX 1	JT 2	Remote sense +	a. MOLEX: 22-01-1022 (5051-02) or 51191-0200 or equivalent b. JST: XHP-2 or equivalent (Note 2)	a. MOLEX: 2759 or 5159 50802 or equivalent b. JST: SXH-001T-P0.6N, SXH-001T-P0.6 or SXH-002T-P0.6 or equivalent
		MX 2	JT 1	Remote sense -		
CN4 (Fan)		MX 1	JT 2	+ V	a. MOLEX: 22-01-1022 (5051-02) or 51191-0200 or equivalent b. JST: XHP-2 or equivalent (Note 2)	a. MOLEX: 2759 or 5159 50802 or equivalent b. JST: SXH-001T-P0.6N, SXH-001T-P0.6 or SXH-002T-P0.6 or equivalent
		MX 2	JT 1	0 V		
CN5		MX 1	JT 2	PG / PF	a. MOLEX: 22-01-1022 (5051-02) or 51191-0200 or equivalent b. JST: XHP-2 or equivalent (Note 2)	a. MOLEX: 2759 or 5159 50802 or equivalent b. JST: SXH-001T-P0.6N, SXH-001T-P0.6 or SXH-002T-P0.6 or equivalent
		MX 2	JT 1	Return		

Note:

- Please see the mechanical drawing for pin assignment.
- Exist with model no. suffixed -J, please see the comparison in Model no. coding.

Thermal Considerations

In order to ensure safe operation of the PSU in the end-use equipment, the temperature of the components listed in the table below must not be exceeded.

Temperature should be monitored using J type thermocouples placed on the hottest part of the component (out of any direct air flow). See Mechanical Details for component locations.

Temperature Measurements at max. amb.	
Component	Max Temperature
T2	110°C
Q9	120°C
D16, D17, D17A	120°C
C14, C16	105°C
C24, C30	105°C