

## SPECIFICATION

For

## SWITCHING POWER SUPPLY

### M/N: MPE-T065

#### Revision History

Version	Revise Date	Change Items
Rev. 01	May. 12. 2014	Established.
Rev. 02	Sep. 5. 2014	<ol style="list-style-type: none"><li>1. Add 7CFM at 70°C environment temperature.</li><li>2. Add mechanical drawing and packing drawing.</li><li>3. Remove TBD at derating curves.</li><li>4. Start up from -10 to -20 degree C.</li></ol>
Rev. 03	Apr. 8. 2015	Added UL and CE logo.
Rev. 04	Nov. 25. 2015	<ol style="list-style-type: none"><li>1. Added "or equivalent" after "Molex".</li><li>2. Added vibration test.</li><li>3. Changed Molex Proposed Terminals from 5176 to 5167.</li></ol>
Rev. 05	Jan. 2. 2018	<ol style="list-style-type: none"><li>1. Changed new form.</li><li>2. Added EN 55032.</li></ol>
Rev. 06	Jul. 2. 2018	Changed mechanical diagram.

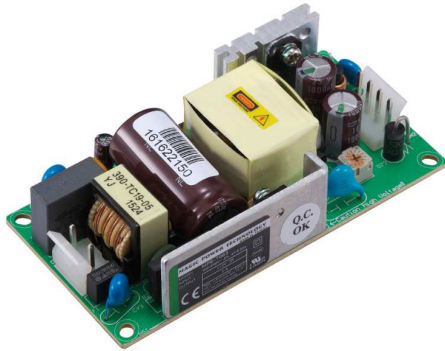

## FEATURES

- ✓ 60W convection-cooled @ 50°C ambient.
- ✓ Ultra-power with low profile 25mm.
- ✓ Compact size 2 x 4 inches.
- ✓ -20°C can start up.
- ✓ High efficiency of up to 91%(MPE-T065 and MPE-T066).
- ✓ No-load power consumption < 0.3W.
- ✓ Class II, also Class I with optional functional ground connected.
- ✓ Design to meet ITE standard IEC, EN, UL 60950-1 2<sup>nd</sup> Edition.
- ✓ Meets EMI CISPR 22 / FCC Part 15 class B.
- ✓ Optional enclosure is available.



## Models & Ratings

Model Number	Wattage	Output Voltage	Min. Current	Rated Current
MPE-T065	60 W	+24 V	0 A	2.5 A

Total Output Power: Max. 60W with convection cooled at 50°C environment temperature. Max. 60W with 7 CFM at 70°C environment temperature (Note 1)

1. Air flow from transformer to the body of PSU with distance 20 mm maximum.
2. Model no. coding:

**MPE-T06X - Y**

①

②

①

X =	Output (V)
3	+12
5	+24
6	+48

②

Y=	Optional Enclosure
blank	Board Type
C	With an Optional Enclosure

Please see paragraph 8 for mechanical outline.

## Summary

Characteristic	Minimum	Typical	Maximum	Units	Notes & Conditions
Input Range	85	115 / 230	264	VAC	Continuous input range.
	130		370	VDC	
Input Frequency	47	50 / 60	63	Hz	At AC input.
Efficiency	88 / 90		91	%	Nominal AC Input Voltage (115/230VAC), rated load, above 1 hr. warm up.
Operation Temperature	0		+70	°C	Derate linearly above 50°C by 1.7% per °C to a maximum temperature of 70°C at 50% load.
Weight		84		g	
Dimensions	101.6 (L) x 50.8 (W) x 25.0 (H) mm, Tolerance +/- 0.5mm.				
EMC	EN 55022 / EN 55032, CISPR 22 & FCC Part 15, EN 61000-3-2, EN 61000-3-3, EN 61204-3, IEC 61000-4-2, IEC 61000-4-3, IEC 61000-4-4, IEC 61000-4-5, IEC 61000-4-6, IEC 61000-4-8, IEC 61000-4-11				
Safety Approvals	IEC 60950-1, 2 <sup>nd</sup> edition, UL 60950-1, 2nd Edition, CSA C22.2 No. 60950-1-07, 2nd Edition				

## Input

Characteristic	Minimum	Typical	Maximum	Units	Notes & Conditions
Input Voltage	85	115 / 230	264	VAC	Continuous input range.
	130		370	VDC	
Input Frequency	47	50 / 60	63	Hz	At AC input.
Input Current			1.5 / 0.8	A	Nominal AC Input Voltage (115VAC/230VAC), rated load.
Inrush Current			30 / 60	A	Nominal AC Input Voltage (115VAC/230VAC), one cycle at 25°C.
No-load power consumption			0.3	W	Nominal AC Input Voltage (240VAC).
Earth Leakage Current			0.25	mA	At input 264VAC, 63Hz, rated load.
Input Protection	One non-user serviceable internally located AC input line fuse. Fuse : 3.15A / 250VAC * 1pcs				

## Output

Characteristic	Minimum	Typical	Maximum	Units	Notes & Conditions
Output Voltage		24		VDC	
Initial Set Accuracy		±1		%	Initial setting accuracy is at Input 115VAC and output at 60% rated load.
Minimum Load		0		A	
Start Up Delay	1	3.5		Sec	Time required for initial output voltage stabilization.
Hold Up Time	16			mS	Nominal AC Input Voltage (115/230VAC), rated load.
Line Regulation		±1.0		%	Less than ±1% at rated load with ±10% changing in input voltage 115VAC.
Load Regulation		±1.0		%	Measured from 60% to 100% rated load and from 60% to 20% rated load (60% ±40% rated load).
Ripple & Noise		240		mV	Rated load, measured by a 20MHz bandwidth limited oscilloscope and the each output is connected with a 10µF Electrolytic Capacitor and a 0.1µF Ceramic Capacitor.
Over / Under Shoot			10	%	Nominal AC Input Voltage (230VAC), rated load.
Overvoltage Protection	For some reason the power supply fails to control itself, the build-in over voltage protection circuit will auto recovery the outputs to prevent damaging external circuits, the trigger point is around 110%~140% of output voltage.				
Short Circuit Protection	Fully protected against output overload and short circuit. Automatic recovery upon of overload condition.				

## General

Characteristic	Minimum	Typical	Maximum	Units	Notes & Conditions
Efficiency	88 / 90		91	%	Nominal AC Input Voltage (115/230VAC), rated load, above 1 hr. warm up.
Isolation	IP to OP	3000		VAC	
	IP to GND	1500		VAC	
Switching Frequency		65		KHZ	

## Environmental

Characteristic	Minimum	Typical	Maximum	Units	Notes & Conditions
Low temperature start up	-20			°C	Without specification stabled. <sup>(Note 1)</sup>
Operating Temperature	0		+70	°C	Derate linearly above 50°C by 1.7% per °C to a maximum temperature of 70°C at 50% load.
Storage Temperature	-40		+85	°C	
Relative Humidity	5		95	%RH	Non-condensing.
Cooling	7			CFM	Forced-cooled when 60W
Operating / Non-Operating Altitude		3000 / 4000		m	
Vibration	0.26		6.09	G	Frequency Type: Sweep Frequency Frequency Range: 10~55 Hz Displacement: 1.0mm Sweep Rate: 60 minute / cycle Number of cycle: 1 cycle / axis Direction: X ,Y and Z axis

Note:

1. Specification stabilized within 20 minutes.

## Derating curve

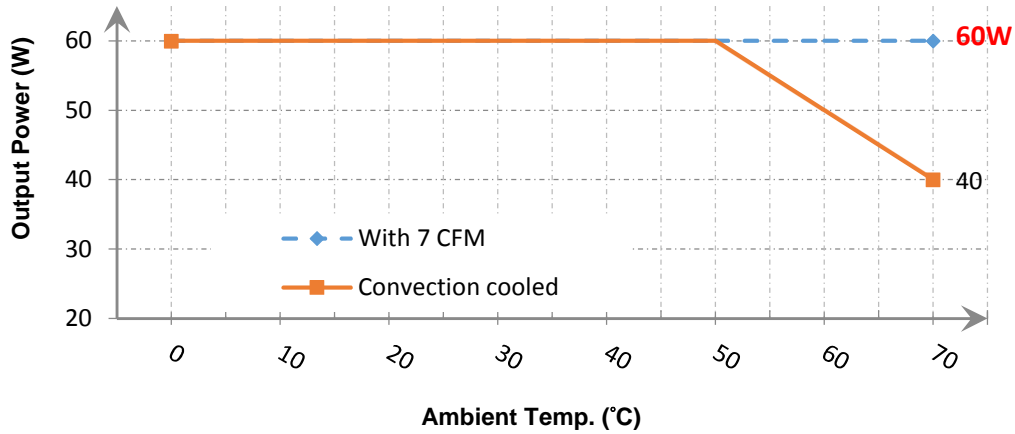

Performance Curves of MPE-T065

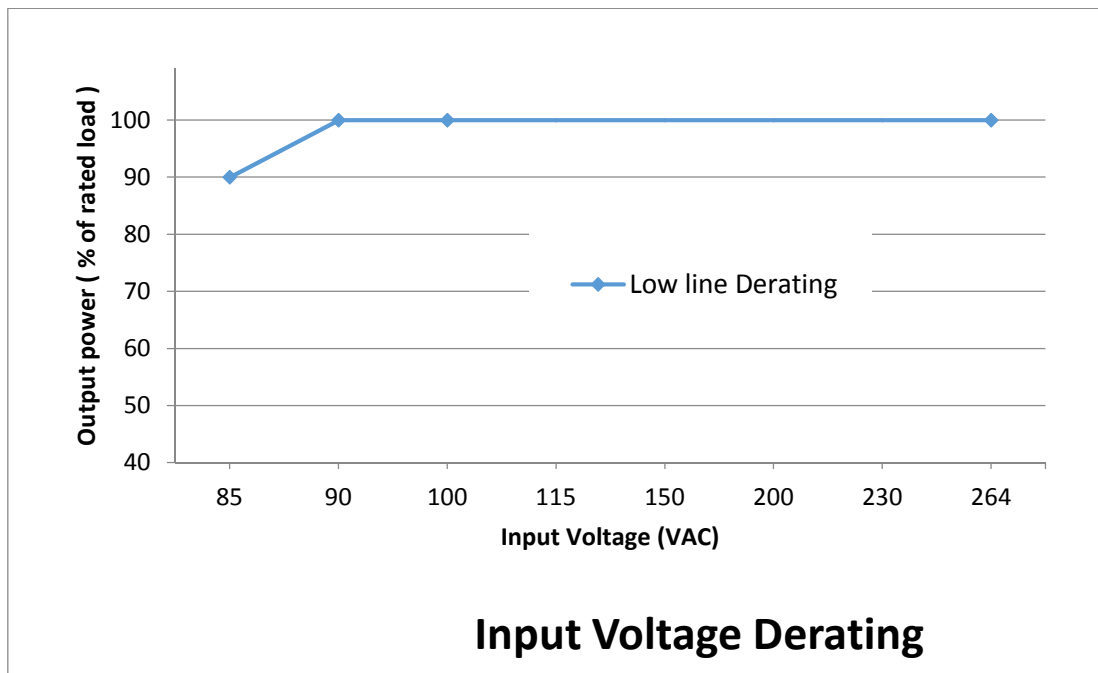

Input Voltage Derating

## EMC: Emissions

Phenomenon	Standard	Class	Notes & Conditions
Conducted	EN 55022 / EN 55032 CISPR 22 & FCC Part 15	B	
Radiated	EN 55022 / EN 55032 CISPR 22 & FCC Part 15	B	
Harmonic	EN 61000-3-2	A	
Voltage Flicker	EN 61000-3-3		

## EMC: Immunity

Phenomenon	Standard	Criteria	Notes & Conditions
ESD	IEC 61000-4-2	A	±8KV air discharge, ±6KV contact discharge
Radiated	IEC 61000-4-3	A	10V/m
EFT	IEC 61000-4-4	A	±2KV Line & PE
Surges	IEC 61000-4-5	A	L-N:±1KV, L/N-PE:±2KV
Conducted	IEC 61000-4-6	A	10V
Power Magnetic	IEC 61000-4-8	A	10A/m
Dips and Interruptions	IEC 61000-4-11	A A A / B C	DIP: >95%, 0.5 cycle DIP: 30%, 25 cycles DIP: 60%, 5 cycles <sup>(Note 2)</sup> INT: >95%, 250 cycles

Note:

- Above specification is applied with output equal or below 60W. For higher output power, please re-confirm with us.
- The test result of input 240Vac / 100Vac is criteria A / B.
- As a build-in type power supply, the power supply needs to be installed in a suitable enclosure to pass the EMI/EMC tests. The final assembly has to comply with the valid EMI/EMC and safety.
- The EMC test conditions are at AC input voltage. It is not been verified at DC input voltage.

## Safety Approvals

Safety Agency	Safety Standard	Notes & Conditions
CB	IEC 60950-1, 2 <sup>nd</sup> edition	Approved
UL/cUL	UL 60950-1, 2nd Edition, CSA C22.2 No. 60950-1-07, 2nd Edition	Approved

## Mechanical Details

M/N: MPE-T065

Unit: mm

SIZE : 101.6(L) x 50.8(W) x 25.0(H)mm, Tolerance +/-0.5mm.

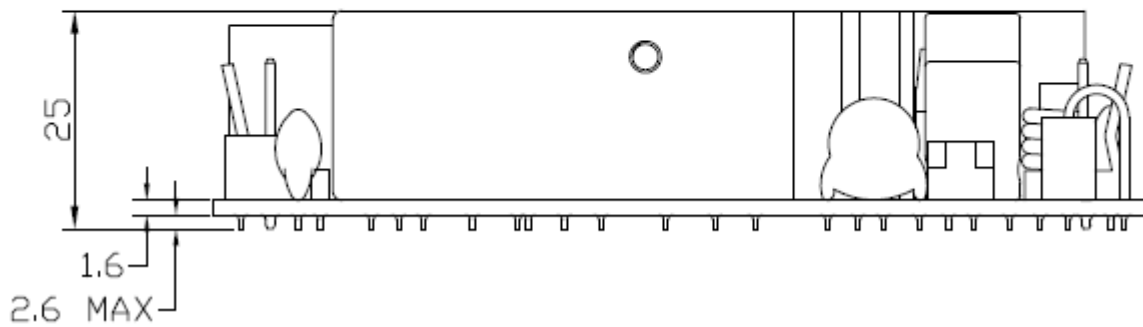
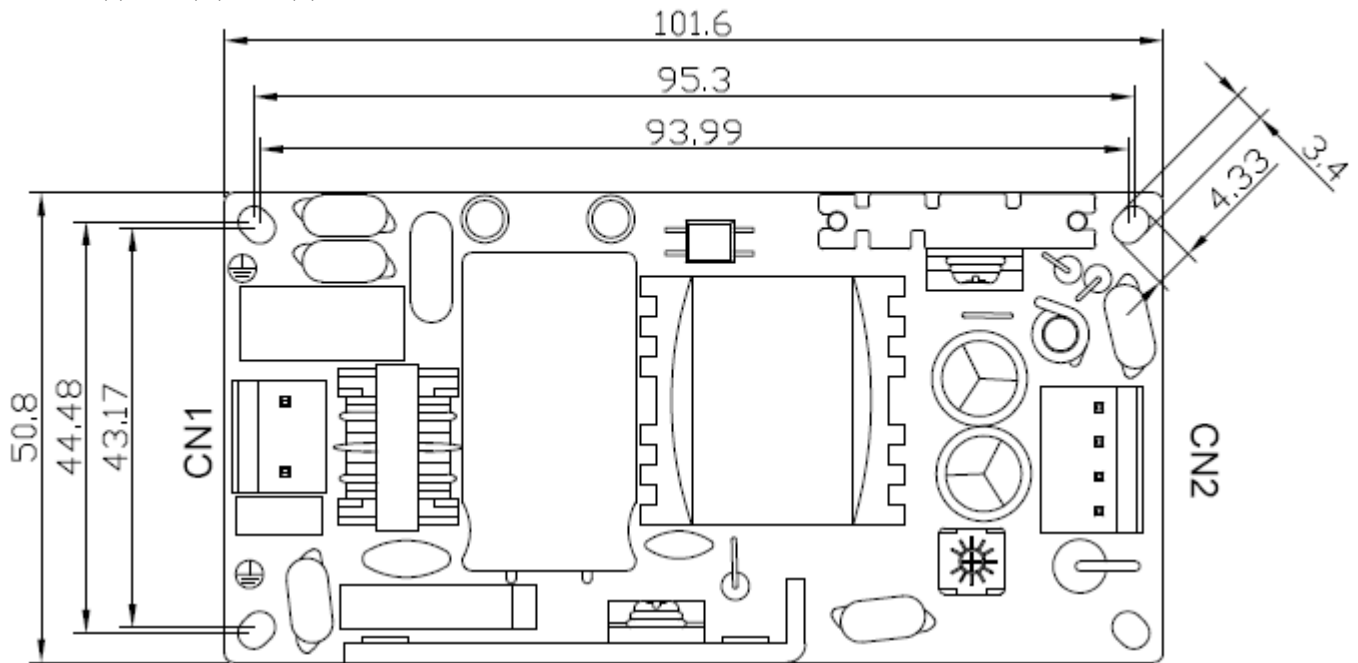

Packing Info.

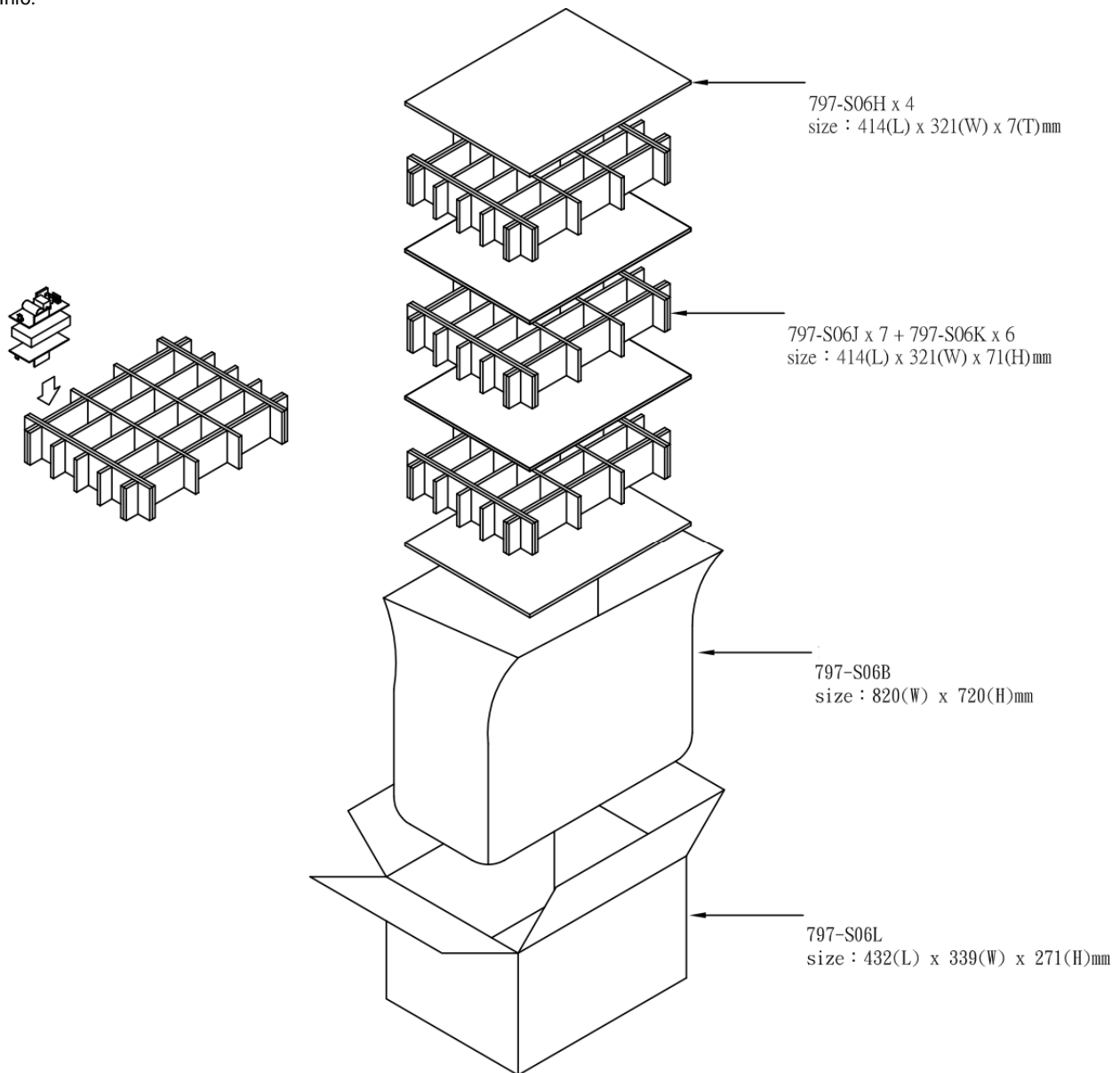

Parameter	Conditions/Description				
Dimension	101.6 (L) x 50.8 (W) x 25 (H) mm, Tolerance +/- 0.5mm.				
Connector & Pin Assignment	Location	Pin	Assignment	Proposed Housing	Proposed Terminals
	CN1 (Input)	3	AC in (L)	MOLEX: 09-05-1031 (5195-05) or 09-52-4034 (5239-05) or equivalent;	MOLEX: 5194 or 5225 2478, 2578,5167 or 5168 or equivalent;
2		N / A			
1		AC in (N)			
CN2 (Output)	4	+ V	MOLEX: 09-05-1061 (5195-06) or 09-52-4064 (5239-06) or equivalent;	MOLEX: 5194 or 5225 2478, 2578,5167 or 5168 or equivalent;	
	3	+ V			
	2	0 V			
	1	0 V			



## Thermal Considerations

In order to ensure safe operation of the PSU in the end-use equipment, the temperature of the components listed in the table below must not be exceeded.

Temperature should be monitored using J type thermocouples placed on the hottest part of the component (out of any direct air flow). See Mechanical Details for component locations.

Temperature Measurements at max. amb.	
Component	Max Temperature
T1	110°C
Q1	120°C
D5	120°C
C4	105°C
C7	105°C